

# AquaScooter2

By

Dylan Cannon, Darin Gilliam, Eli Palomares, Elizabeth Tyler,  
Jiyan Wang, Tyler Winston  
Team 8

## Problem Definition

Document

*Submitted towards partial fulfillment of the requirements for  
Mechanical Engineering Design I – Fall 2014*



Department of Mechanical Engineering  
Northern Arizona University  
Flagstaff, AZ 86011

**ABSTRACT**

The objective of this proposal is to present the problem definition and schedule of the Aqua Scooter capstone project. The Aqua Scooter has a two cycle gas powered engine that, as of January 2010, the EPA's regulations prevent future sales. The capstone team needs to design and engineer a new engine which meets current and immediate future EPA regulations.

This report gives the background information pertaining to the emissions along with the current technology and some possible solutions. The constraints provided by the client to the Aqua Scooter team are given and some particular. Finally, a schedule of deliverables is provided for the first semester of the project.

## Table of Contents

1. Introduction .....	1-3
1.1.1 Client and Product Information.....	1-2
1.1.2 Background .....	1-2
1.1.3 Aqua Scooter Emissions .....	2
1.1.4 Why Test for Emissions.....	2
1.2 Current Technology Summary.....	2-3
1.2.1 Material Properties.....	2
1.2.2 Possible Solution.....	2
1.2.3 Summary .....	2
2. Problem Statement .....	5-7
2.1 Constraints .....	5
2.2 Quality Function Deployment.....	5
2.3 Weight .....	6
2.4 House of Quality .....	7
3. Testing Environment.....	7
4. Gantt Chart.....	8-9
5. Conclusion .....	9
References.....	10
Appendix A.....	11

## **List of Figures and Tables**

### **Figures**

Figure 1: Aqua Scooter with Components	1
Figure 2: Aqua Scooter with Components and Extension	2
Figure 3: Gantt Chart	8
Figure A1: Components Description	11
Figure A2: Components Description	11

## **Tables**

Table 1: Quality Function Deployment	5
Table 2: House of Quality	6

## 1. INTRODUCTION

### 1.1.1 Product and Client Information

Aqua Scooter is a portable, submersible, gasoline powered water craft for individual use. Aqua Scooter is family owned and operated out of Sedona, Arizona. The client for this project (R.S.W. /D.I. Inc) is the owner and CEO of Aqua Scooter. The current device design is shown in Figure 1 and Figure 2. The numbered component descriptions are found in the Appendix of this report. The design incorporates a 2-stroke engine which provides approximately 2HP of power to the user. The scooter provides around 5 hours of operating time with a 2 L fuel tank capacity.

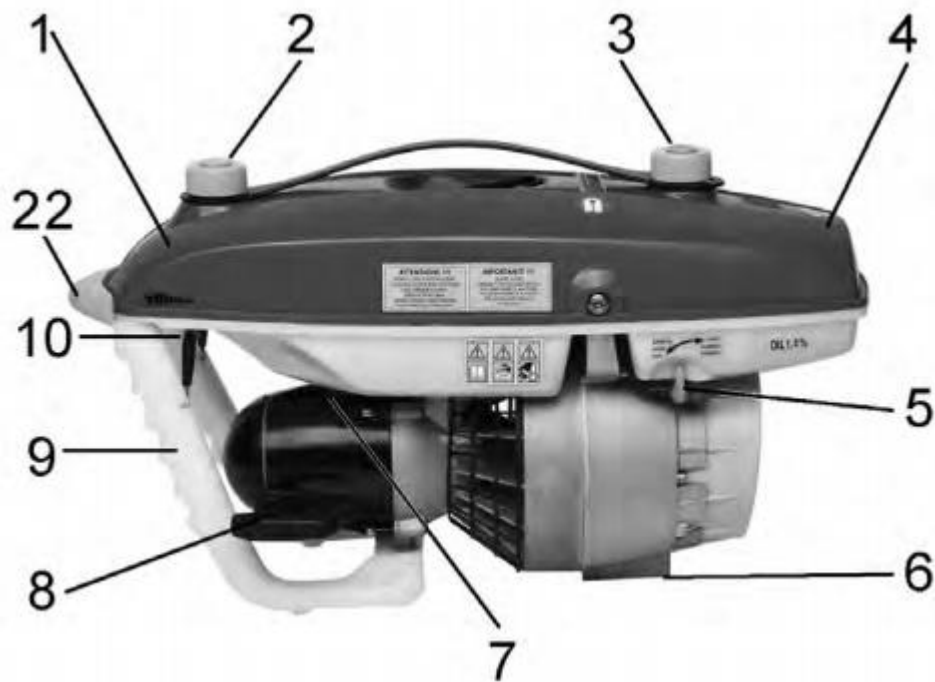

**Figure 1:** Aqua Scooter side view with designated components

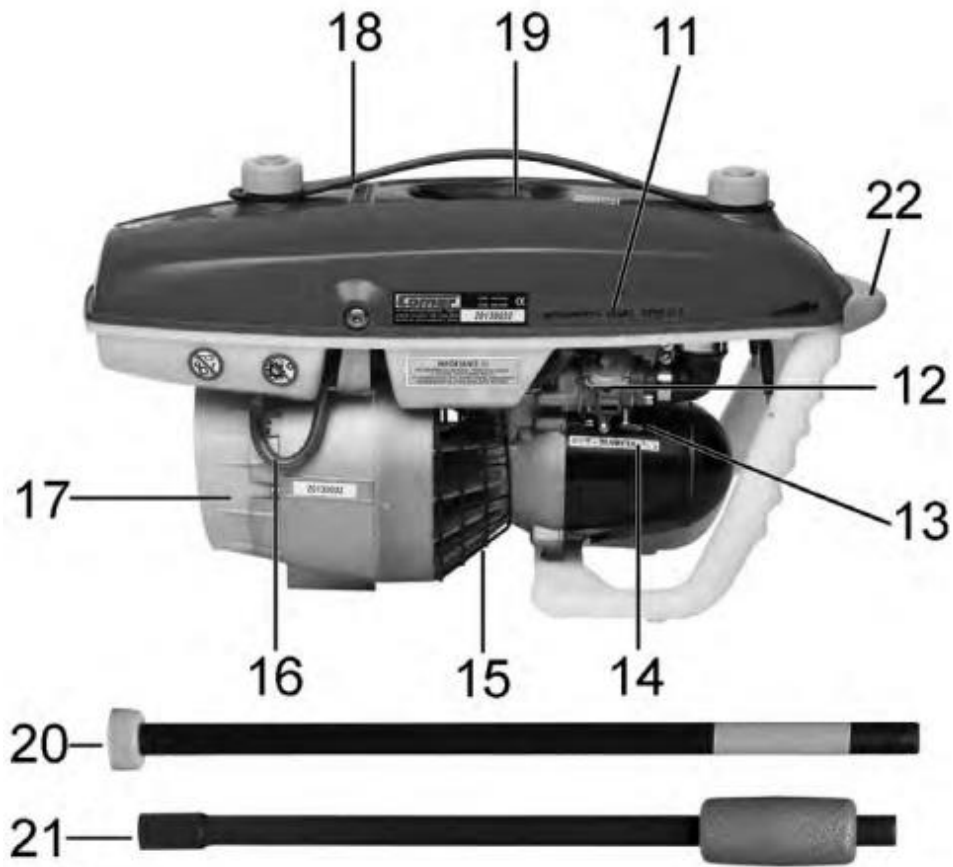

**Figure 2:** Aqua Scooter with designated components and snorkel extension

### 1.1.2 Background

A chemical technician by the name of Bernd Boettgers wanted to escape from East Germany, but he knew he would need some type of machine to help pull him through the sea. His first attempt to test his “water-machine” resulted in an arrest and jail time of three months. He was convicted of an illegal attempt at border crossing. After he was released, he decided to work on a second machine, and after a year of building, he entered the sea in September of 1968 for his second attempt. He traveled by water for six hours, two of which were done fully submerged under the sea, until he was finally spotted by the Danish Lightship, named Gedser. His successful escape broke into the European Press, and by the end of January in 1978 the “Aqua Scooter” had been brought to the United States and the first commercial prototype was successfully tested.

### **1.1.3 Aqua Scooter Emissions**

The current 2-stroke, direct drive engine does not comply with EPA regulations. As a result, the client is unable to sell the Aqua Scooter in the United States. The current emission standards that the Aqua Scooter must meet are as follows:

- It must have less than or equal to 30 g of hydrocarbons
- Less than or equal to 490 g of carbon monoxide per kilowatt hour.

Emissions testing will be done by either the Arizona Department of Transportation, or Arizona Game and Fish Department.

### **1.1.4 Why Test for Emissions**

A good questions one might find themselves asking, is why test for emissions? What benefits does it bring to the customer, if any, and why is it important to pass? It turns out that passing an emissions test and just taking the test in general, brings several advantages. Here are three reasons why emissions testing are very important:

1. It identifies necessary repairs to improve vehicles performance and fuel economy
2. It improves air quality by reducing carbon monoxide, hydrocarbons, and nitrogen oxides
3. If emission controls are not working properly, testing ensures that owners make the appropriate repairs to aid in the reduction of ground level ozone

Although testing for emissions improves the air quality for everyone around you, it also turns out that emission testing also brings several benefits to the customers themselves.

## **1.2 Current Technology**

The group researched two and four stroke engines for this project. The current technology on the market is available to implement in a possible solution for our client. Options available in the current market are conventional gas models or alternatives such as propane or compressed natural gas.



### **1.2.1 Material Properties**

The materials for the new design need to be lightweight so that the Aqua Scooter can float. The new scooter should also have materials strong enough to support its own weight and handle the pressure exerted when submerged to maximum operating depth. The manufacturing of the device will also need to be considered when selecting the materials so that the cost of making the new design is still feasible.

### **1.2.2 Possible Solutions**

Current solutions to the problem are either a four stroke internal combustion engine or a fuel injected two stroke internal combustion engine. The issue with the four stroke solution is implementing an engine that is light enough to meet the weight and thrust constraints.

Research to resolve this issue has been focused primarily on compressed fuels contained in cylinders. There may be an advantage in losing the weight of a gas tank to lighten the overall weight of the machine. As for the two stroke solution, current technology is available that monitors and controls fuel intake to minimize the unburned amounts of fuel that enter the atmosphere as seen with previous two stroke models. Fuel system modification, along with implementing biodegradable two stroke oils that are also recently available, can be a viable solution in designing a product that meets current EPA requirements.

### **1.2.3 Summary**

The Aqua Scooter is a machine that has been useful for over four decades. The power system that the machine has used since its origin is obsolete based on current environmental regulations. In order for the Aqua Scooter to keep fulfilling the legacy it has created, the team has been tasked with redesigning the device. This will be accomplished through testing and implementation of state of the art technology in the field of materials, as well as internal combustion engines.

## **2. PROBLEM STATEMENT**

The current design for the Aqua Scooter does not comply with the most recent Environmental Protection Agency's regulations on two-stroke engines for recreational use. In order to have a marketable product, this team will design a hydrodynamic, inexpensive, aesthetically pleasing Aqua Scooter, with a marine engine that complies with EPA regulations.

### **2.1 Constraints**

The prototype needs to meet certain constraints the team has determined based off communication with the client. The constraints are the following:

- Gasoline powered
- Engine housing must be metal
- Muffler housing must be metal
- Throttle control
- Exhaust valve
- Starter assembly made of plastic and metal
- Plastic propeller protection
- Control handle
- Plastic fuel tank, with minimum volume of ½ gallon
- Must have a dry weight of 18 lbs. or less
- Must be buoyant enough to float itself
- Must provide at least 50 lbs. thrust
- Must cost no more than \$450 per scooter manufactured

## 2.2 Quality Function Deployment (QFD)

**Table 1:** Quality function deployment showing the engineering requirements and customer needs.

Aqua Scooter QFD Matrix	Weight	Buoyancy	Fuel Capacity	Thrust	Exhaust emission	Operating Life	Warranty	Cayago Seabob	Seadoo Seascooter
Aesthetically pleasing	X		X					O	O
Child safe	X	X		X	X				O
Lightweight	X	X	X	X					
Floats	X	X	X					O	O
Propels operator through water				X	X			O	O
Runs for extended period			X						
Meets current EPA regulations					X	X	X	O	O
units	lb.	lb.	gal.	lb.	g/kW-h	Hours/Years	Hours/ Months		
	>= 18	>= 18	>= 0.5	>= 50	<=30 of Hydrocarbon, <=490 of Carbon Monoxide	>= 350/5	>= 175/30		

### 2.3 QFD Summary

The QFD matrix (Table 1) above is useful for correlating the needs of the customer to the requirements that the team can quantify. The requirements that need the most attention based on the matrix are exhaust emissions, fuel capacity, weight, buoyancy, and thrust. The exhaust emissions carry a significant amount of weight due to the fact that without falling below the constraint, the new design will not meet EPA regulations. This is not a desirable outcome because that is the main problem the current Aqua Scooter design is facing. Secondly, the weight of the machine is important because that affects the buoyancy, as well as how much exhaust gas the engine emits. For example, the heavier the device is, the harder the engine will have to work to propel the device and operator through the water. Moving forward, keeping the needs, requirements and constraints in mind will be crucial in developing an effective alternative to the current Aqua Scooter model.

### 2.4 House of Quality

The house of quality (Table 2) correlates the engineering requirements that are listed for this particular project. If the requirement is positively correlated, indicating that the increase of a particular item produces the same effect on another requirement, a (+) symbol is shown. If the requirements are negatively correlated, a (-) symbol is shown. If there is no correlation the space is left blank.

**Table 2:** House of quality, which correlates engineering requirements

Weight						
Buoyancy	-	+				
Fuel Capacity						+
Thrust		+		-		
Exhaust Emission	+		+			
Operating Life				-		
Warranty	-					

### 3. TESTING ENVIRONMENT

Since the Aqua Scooter will need to be completely submerged in water, it is only fitting to test the prototype in a body of water large enough to assess the functionality. All the aspects of testing (i.e. thrust, weight, and functionality of all parts, fuel efficiency, and buoyancy) will take place in Lake Mary. Additionally, final testing will be conducted in a saltwater environment that is identical to the environment where our product will be marketed for use. The team will plan to test the design in the Pacific Ocean in San Diego.

To insure that the prototype engine will meet EPA regulations, emissions testing will take place at the facilities of Arizona Department of Transportation, or Arizona Game and Fish Department. They engine will be attached to a device where the results will validate the condition of emissions and whether the engine will comply with EPA requirements.

### 4.0 GANTT CHART

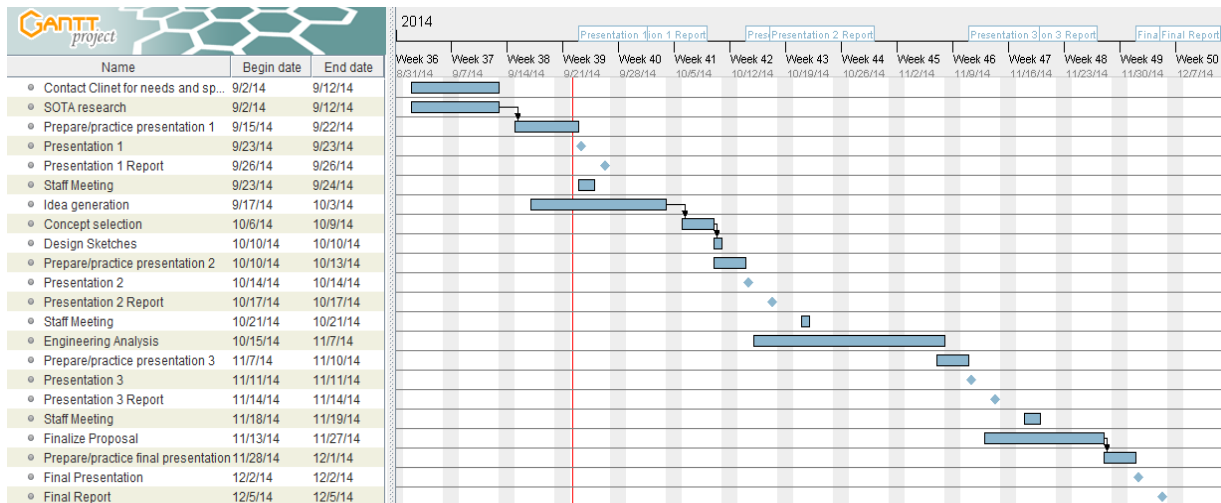

**Figure 3:** Gantt Chart and schedule of major deliverable and tasks for project.

Figure 3 displays the Gantt chart which illustrates an estimated timeline for the first semester of the Aqua Scooter prototype design. The timeline is broken down into tasks and deliverables. Tasks are shown as blue bars and deliverables are shown as blue diamonds in Figure 3. The deliverables include presentations and reports. Based on the

materials required for the presentations, the tasks are laid out in an order such that tasks relevant to specific presentations are completed before the presentation date. This layout ensures everything is completed while also ensuring there are specific timelines for certain tasks. The Gantt chart is a work in progress and may end up changing as the semester progresses to reflect changes in due dates and newly recognized tasks relevant to the prototype design and final proposal for Aqua Scooter.

## **5.0 CONCLUSION**

The client, R.S.W. /D.I. Inc. currently manufactures a product that does not meet current United States' EPA regulations. The objective of this project is to design, engineer, and test an engine that will exceed the current EPA regulations. The most important points to consider for the design of a prototype are to adhere to the EPA regulations, keep dry weight of device under 18 lbs. and provide a capacity of a minimum of 50 lbs. of thrust. Additionally, the team must keep the manufacturing cost per scooter under \$450. The QFD, and House of Quality will ensure that the team complies with the needs of the client, while the Gantt chart will keep the team on track with the deliverable and milestone schedules

## REFERENCES

- [1] Aqua Scooter Manual. Comer SPA. Accessed 10 Oct 2014.  
[http://www.aquascooter.it/AQUA\\_GB.pdf](http://www.aquascooter.it/AQUA_GB.pdf)
- [2] B. Douville, P. Ouellette, A. Touchette and B. Ursu, "Performance and emissions of a two-stroke engine fueled using high-pressure direct injection of natural gas," in *1998 SAE International Congress and Exposition, February 23, 1998 - February 26, 1998*, .
- [3] P. Duret, A. Ecomard and M. Audinet, "A new two-stroke engine with compressed-air assisted fuel injection for high efficiency low emissions applications," in *International Congress and Exposition, February 29, 1988 -March 4, 1988*, .
- [4] H. Huang, M. Jeng, N. Chang, Y. Peng, J. H. Wang and W. Chiang, "Improvement of exhaust emissions from a two-stroke engine by direct injection system," in *International Congress and Exposition, March 1, 1993 -March 5, 1993*, .
- [5] W. Mitianiec, "Direct injection of fuel mixture in a spark ignition two-stroke engine," in *SAE 2002 World Congress, March 4, 2002 - March 7, 2002*, .
- [6] K. Morikawa, H. Takimoto, T. Kaneko and T. Ogi, "A study of exhaust emission control for direct fuel injection two-stroke engine," in *Small Engine Technology Conference and Exposition, September 28, 1999 -September 30, 1999*, .
- [7] P. Rochelle and W. Perrard, "Fuel consumption and emission reduction of a small two-stroke engine through air-assisted fuel injection and delayed-charging," in *International Congress and Exposition, March 1, 1999 -March 4, 1999*, .
- [8] Sea-Doo. (2013) *RS Comparison* [Online]. Available FTP:  
[http://www.seadooseascooter.com/RS\\_CMS/index.php?option=com\\_content&view=article&id=22&Itemid=41](http://www.seadooseascooter.com/RS_CMS/index.php?option=com_content&view=article&id=22&Itemid=41)
- [9] A. Dave, *Development of a Reed Valve Model for Engine Simulations for Two-Stroke Engines*, 1st ed. , SAE International, 2004.
- [10] L. Arnone, M. Janeck, M. Marcacci, R. Kirchberger, M. Pontoppidan and R. Busi, "Development of a direct injection two-stroke engine for scooters," in *Small Engine Technology Conference and Exhibition, November 28, 2001 - November 30, 2001*, .

## APPENDIX

- 1 - AIR TANK
- 2 - AIR TANK PLUG FOR SNORKEL CONNECTION
- 3 - FUEL TANK PLUG
- 4 - FUEL TANK
- 5 - FUEL VALVE
- 6 - EXHAUST GAS OUTLET
- 7 - FUEL PIPE
- 8 - STARTER HANDLE
- 9 - STEERING HANDLE
- 10 - THROTTLE LEVER

**Figure A1:** List of components of Aqua Scooter

- 11 - **"AVVIAMENTO - START - STOP"** POSITIONS
- 12 - CARBURETTOR TO CARB - EPA STANDARDS
- 13 - "START AND RUN" LEVER
- 14 - **"RUN/MARCIA"** POSITIONS
- 15 - PROTECTIVE GRILLE C €
- 16 - FUEL TANK BREATHER PIPE
- 17 - PROPELLER GUARD AND WATER DEFLECTOR C €
- 18 - CARRY HANDLE
- 19 - SPARK PLUG
- 20 - AIR INTAKE TUBE (SNORKEL)
- 21 - SNORKEL EXTENSION
- 22 - RUBBER BUMPER

**Figure A2:** Additional list of components for Aqua Scooter